

# CHERUBINI

tocco italiano dal 1947

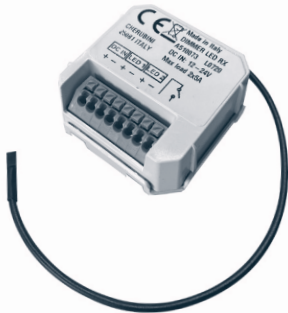

## A510073 DIMMER LED RX

Dispositivo a bassa tensione per comandare 2 barre LED

IT

Low voltage device to control 2 LED bars

EN

Niederspannungsgerät zur Steuerung von 2 LED-Schranken

DE

Dispositif à basse tension pour commander 2 barres LED

FR

Dispositivo de baja tensión para controlar 2 tiras LED

ES

CE ISTRUZIONI - INSTRUCTIONS - EINSTELLANLEITUNGEN - INSTRUCTIONS - INSTRUCCIONES



## Table of contents:

Safety instructions .....	p. 17
Technical features .....	p. 17
Electrical connections .....	p. 17
Compatible remote controls .....	p. 18-19
Key to symbols.....	p. 19

### PROGRAMMING:

<b>to series Skipper - series Giro - series POP remote controls</b> .....	p. 20
Setting the first remote control .....	p. 20
Automatic disabling of the first remote control setting function.....	p. 20
Setting of additional remote controls.....	p. 20
Remote control memory clearing .....	p. 21
Full memory clearing.....	p. 21
<b>to A530058 remote control with 4 independent channels..</b> .....	p. 22
Setting the remote control directly on the receiver .....	p. 22
Programming from another remote control .....	p. 23
Single channel memory clearing .....	p. 23

### OPERATING MODES:

<b>Mode 1D (duplicate load)</b> .....	p. 24
to Skipper / POP series remote controls .....	p. 24
to Giro series remote controls.....	p. 24
to A530058 remote control with 4 independent channels .....	p. 25
to button connected to the wired switch .....	p. 25
<b>Mode 2L (two independent loads)</b> .....	p. 26
to Skipper / POP series remote controls .....	p. 26
to Giro series remote controls.....	p. 26
to A530058 remote control with 4 independent channels .....	p. 27
to button connected to the wired switch .....	p. 27
Change mode from 1Dd to 2L and vice versa .....	p. 28
Special function: short-term setting of a remote control.....	p. 28
EU Declaration of conformity .....	p. 68

## SAFETY INSTRUCTIONS

- Only professional technicians must perform installation, complying with all safety instructions, especially those regarding electrical connections.

## TECHNICAL FEATURES

- |                         |                  |
|-------------------------|------------------|
| - Power Supply          | 12V - 24 V dc    |
| - Max power 12 V        | 2x60 W           |
| - Max power 24 V        | 2x120 W          |
| - Decoder System        | CRC              |
| - Operating temperature | -10°C +55°C      |
| - Dimensions (mm)       | 48,5 x 48,5 x 22 |
| - Weight                | 30 g             |
| - Protection degree     | IP20             |

## ELECTRICAL CONNECTIONS

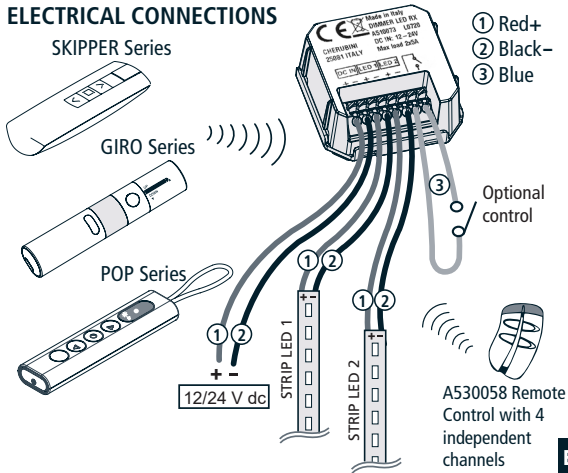

# COMPATIBLE REMOTE CONTROLS



## GIRO

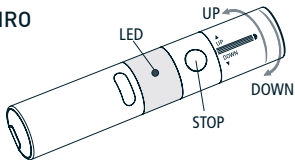

## GIRO Wall

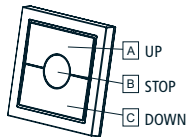

## GIRO Plus

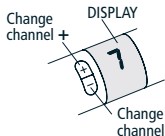

## GIRO Lux

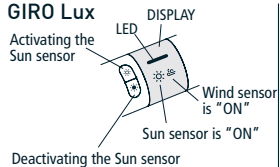

## GIRO P-Lux

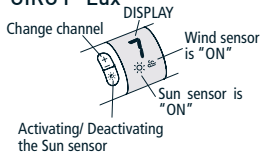

SKIPPER  
SKIPPER **LUX**  
SKIPPER **PLUS**  
SKIPPER **P-LUX**

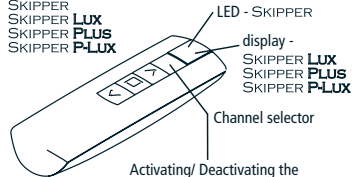

Activating/ Deactivating the Sun sensor - SKIPPER **LUX**  
SKIPPER **P-LUX**

SKIPPER **LCD**  
SKIPPER **SensO**

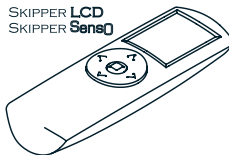

A530058 Remote Control with 4 independent channels



Check the specific instruction book

To prevent accidental changes to the programming of the motor during the daily use of the remote control, the possibility of programming is disabled automatically 8 hours after sending the last sequence (A+B or B+C).

**POP  
POP Lux**

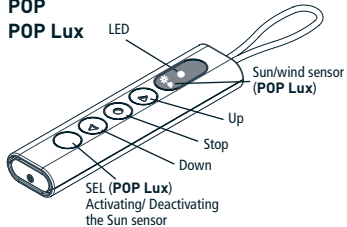

**POP Plus  
POP P-Lux**

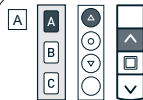
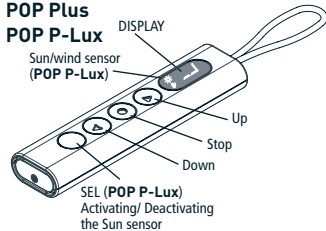

Press button A

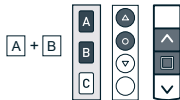

Press buttons A and B  
at the same time

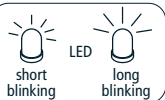

**KEY TO SYMBOLS**

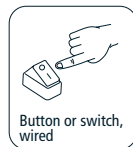
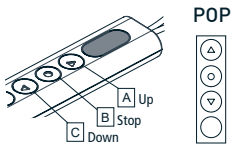
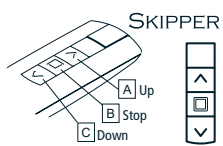
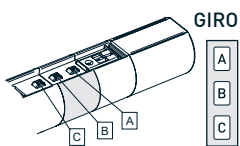

## PROGRAMMING TO SERIES SKIPPER - SERIES GIRO - SERIES POP REMOTE CONTROLS

### SETTING THE FIRST REMOTE CONTROL

This operation can only be performed when the receiver is new, or after a total delete of the memory. The operation can be performed in two ways:

T1: First remote control to be set

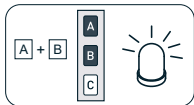

T1 short

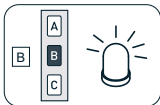

T1 short

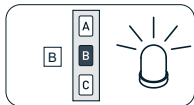

T1 (2 sec) long

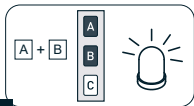

T1 short

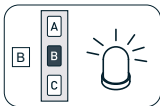

T1 short



(2 sec) long

### AUTOMATIC DISABLING OF THE FIRST REMOTE CONTROL SETTING FUNCTION

Every time you connect the control unit you have 3 hours to store the first remote control. After this time, the ability to store the remote control is disabled. To reset the timer of the function you have to disconnect and reconnect the control unit.

### SETTING OF ADDITIONAL REMOTE CONTROLS

Up to 15 remote controls can be set.

Tn: Already programmed remote control

Tx: Additional remote control

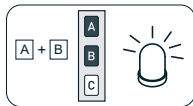

Tn short

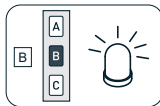

Tn short

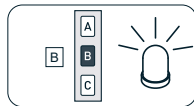

Tx (2 sec) long

## REMOTE CONTROL MEMORY CLEARING

It is possible to delete singly all the memorized remote controls. When the last one is deleted the receiver initial condition is restored. The same applies to the single channels of a multichannel remote control: just select the channel to cancel. Tn: Remote control to be cleared.

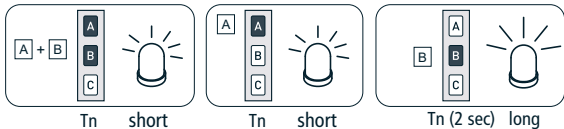

This sequence deletes the remote control from all the associated receivers.

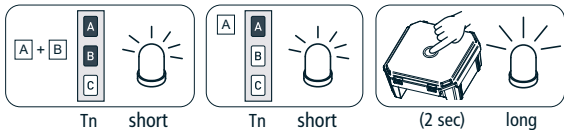

This sequence deletes the remote control from a single receiver.

## FULL MEMORY CLEARING

The full memory clearing can be performed in two ways:

### 1) WITH THE REMOTE CONTROL

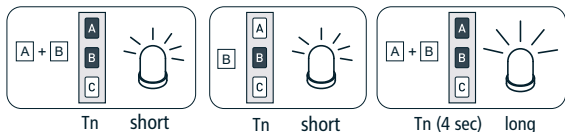

### 2) WITH THE SET BUTTON

Use this option only in case of emergency or when no working remote control is available. Use the SET button on the device to clear the memory.

The procedure sequence is as follows:

- 1) Disconnect the power from the receiver, for example at the main breaker switch, and wait at least 10 seconds.
- 2) Reconnect the power to the receiver holding down the SET button; the Led will blinking briefly.



- 3) Disconnect the power from the receiver.
- 4) Reconnect the power to the receiver holding down the SET button; after 4 seconds the Led will blinking briefly followed by a longer blinking.
- 5) Release the SET button.

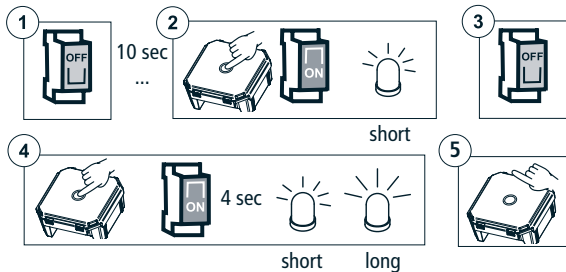

The procedure also automatically deletes the associated remote control A530058.

## A530058 REMOTE CONTROL WITH 4 INDEPENDENT CHANNELS

### SETTING THE REMOTE CONTROL DIRECTLY ON THE RECEIVER

It is possible to associate a remote control with 4 independent channels with a receiver. The receiver should be programmed on a button that is not associated with another device.

- Press the SET button for at least 4 seconds.
- The Led lights on to indicate that it is ready for programming.
- Within 4 seconds press the button to be programmed on the A530058 remote control for at least 2 seconds.
- The programming Led will respond with three flashes (short, short, long).

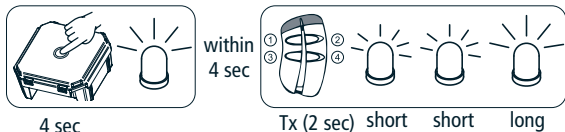

## PROGRAMMING FROM ANOTHER REMOTE CONTROL

The A530058 remote control may be set from another remote control that has already been programmed.

- Press the A and B buttons at the same time.
- The Led lights on with a short blinking.
- Then press the B and C buttons at the same time.
- The Led lights on again with a short blinking.
- Then, press the desired button on the A530058 remote control for at least 2 seconds.
- The programming Led responds with a long blinking.

Tn: Already programmed remote control

Tx: Additional remote control

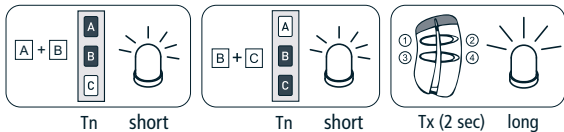

## SINGLE CHANNEL MEMORY CLEARING

It is possible to delete each memorized channel individually by selecting the channel to be deleted during the last step of the following sequence. To delete all channels, repeat the sequence as many times as necessary.

Tn: Already programmed remote control

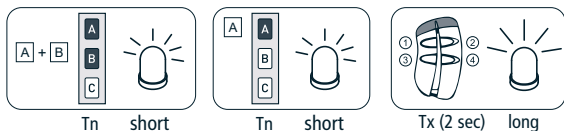

## OPERATING MODES

This Dimmer allows you to configure and control the two outputs with two different modes:

- **1D** a duplicate load (factory setting).
- **2L** two independent loads.

To change mode, see page 28.

### MODE 1D (duplicate load)

This mode allows you to control both Dimmer outputs together.

### Skipper / POP series remote controls

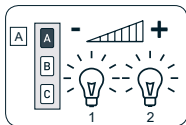

**DIM+ 1/2**

Button A (up) turns on and increases the brightness of outputs 1 and 2.

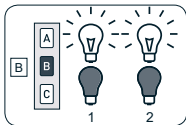

**ON/OFF 1/2**

Button B (stop) turns outputs 1 and 2 on and off.

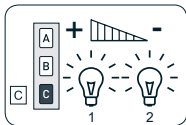

**DIM- 1/2**

Button C (down) turns on and decreases the brightness of outputs 1 and 2.

### Giro series remote controls

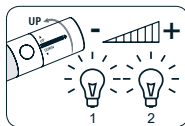

**DIM+ 1/2**

Rotate in the UP direction to turn on and increase the brightness of outputs 1 and 2.

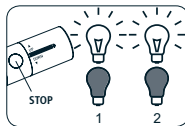

**ON/OFF 1/2**

The STOP button turns outputs 1 and 2 on and off.

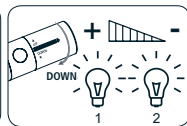

**DIM- 1/2**

Rotate in the DOWN direction to turn on and decrease the brightness of outputs 1 and 2.

### A530058 remote control with 4 independent channels

Each time the programmed button is pressed briefly (<1 sec), outputs 1 and 2 are turned on and off, as indicated in the sequence:

- The first time the button is pressed it turns on both outputs.
- The second time the button is pressed it turns off both outputs.

Command sequence example:

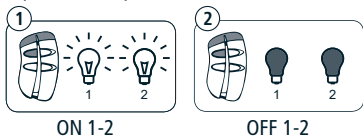

With the outputs switched on, each time the programmed button is pressed long (>1 sec), outputs 1 and 2 both change in brightness: the first time they increase in intensity, the next time they decrease and so on, alternating.

### Button connected to the wired switch

Each time the button is pressed briefly (<1 sec), outputs 1 and 2 are turned on and off, as indicated in the sequence.

- The first time the button is pressed it turns on both outputs.
- The second time the button is pressed it turns off both outputs.

Command sequence example:

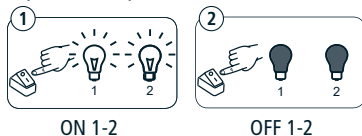

With the outputs switched on, each time the button is pressed long (>1 sec), outputs 1 and 2 both change in brightness: the first time they increase in intensity, the next time they decrease and so on, alternating.

## MODE 2L (two independent loads)

This mode allows you to control the Led Dimmer RX outputs independently from each other.

### Skipper/ POP series remote controls

Button B (stop) turns outputs 1 and 2 on and off in the sequences below:

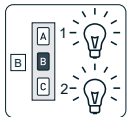

ON 1/2

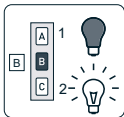

OFF 1/ON 2

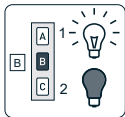

ON 1/OFF 2

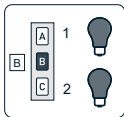

OFF 1/2

With the outputs switched on, each time the button is pressed long (>1sec), outputs 1 and 2 both change in brightness as in the indications below:

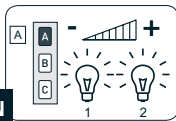

**DIM+ 1/2**  
Button A increases the brightness of the outputs that are on.

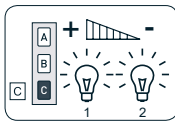

**DIM- 1/2**  
Button C decreases the brightness of the outputs that are on.

## Giro series remote controls

The STOP Button turns outputs 1 and 2 on and off, as in the sequence:

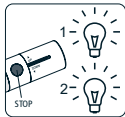

ON 1/2

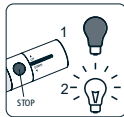

OFF 1/ON 2



ON 1/OFF 2

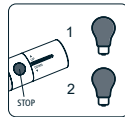

OFF 1/2

With the outputs switched on, with each long rotation (>1 sec), outputs 1 and 2 both change in brightness as in the indications below:

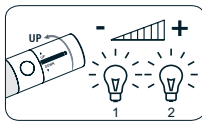

DIM+ 1/2

Rotate in the UP or DOWN direction to change the brightness of outputs 1 and 2.

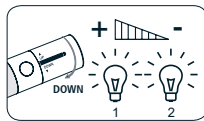

DIM- 1/2

## A530058 remote control with 4 independent channels

Each time the programmed button is pressed briefly (<1 sec), outputs 1 and 2 are turned on and off, as indicated in the sequence:

- The first time the button is pressed it turns on both outputs.
- The second time the button is pressed it turns off output 1 and on output 2.
- The third time the button is pressed it turns on output 1 and turns off output 2.
- The fourth time the button is pressed it turns off both outputs.

Command sequence example:



With the outputs switched on, each time the programmed button is pressed long (>1 sec), outputs 1 and 2 both change in brightness: the first time they increase in intensity, the next time they decrease and so on, alternating. The switched off outputs do not change.

## Button connected to the wired switch

Each time the button is pressed briefly (<1 sec), outputs 1 and 2 are turned on and off, as indicated in the sequence.

- The first time the button is pressed it turns on both outputs.
- The second time the button is pressed it turns off output 1 and on output 2.
- The third time the button is pressed it turns on output 1 and turns off output 2.
- The fourth time the button is pressed it turns off both outputs.

Command sequence example:



With the outputs switched on, each time the button is pressed long (>1 sec), outputs 1 and 2 both change in brightness: the first time they increase in intensity, the next time they decrease and so on, alternating. The switched off outputs do not change.

## CHANGE MODE FROM 1D TO 2L AND VICE VERSA

The Dimmer LED RX with 2 outputs is factory preset for 1D mode. The mode may be changed from 1D to 2L and vice versa immediately after turning it on.

To change the 1D Mode to the 2L mode, do the following:

- 1) Disconnect the power and wait at least 10 seconds.
- 2) Reconnect the power.
- 3) Stand by for the Led signal that indicates the current mode:
  - 1 blinking for the 1D mode.
  - 2 blinkings for the 2L mode.
- 4) Within 4 seconds press the SET button: the Led shows the new mode with the relative number of blinkings.

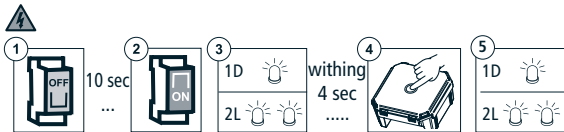

## SPECIAL FUNCTION: SHORT-TERM SETTING OF A REMOTE CONTROL

This function makes it possible to store a remote control temporarily. A later final saving of the remote control will be possible using the appropriate command sequence (see: "SETTING THE FIRST REMOTE CONTROL"). The operations described below can be carried out only when the receiver has just come out of the factory or after a full memory clearing (see: "FULL MEMORY CLEARING"). The receiver makes the following operations possible only within the time limits described in order to make sure that the short-term setting is used only in the installation or factory setting phase and not during daily use. Power up the receiver, make sure that no other receivers having an empty memory are powered up in the same operating range. Within 30 seconds after start, press the B and C buttons simultaneously until the motor gives a confirmation signal. The remote control will remain stored for 5 minutes, while the receiver is powered up. After 5 minutes or when the receiver has its power cut off, the remote control will be cancelled.

T1: First remote control to be set

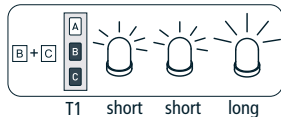

### **IT DICHIARAZIONE DI CONFORMITÀ UE**

CHERUBINI S.p.A. dichiara che il prodotto è conforme alle pertinenti normative di armonizzazione dell'Unione:

Direttiva 2014/53/UE, Direttiva 2011/65/UE.

Il testo completo della dichiarazione di conformità UE è disponibile facendone richiesta sul sito: [www.cherubini.it](http://www.cherubini.it).

### **EN EU DECLARATION OF CONFORMITY**

CHERUBINI S.p.A. declares that the product is in conformity with the relevant Union harmonisation legislation:

Directive 2014/53/EU, Directive 2011/65/EU.

The full text of the EU declaration of conformity is available upon request at the following website: [www.cherubini.it](http://www.cherubini.it).

### **DE EU-KONFORMITÄTSERKLÄRUNG**

CHERUBINI S.p.A. erklärt der produkt erfüllt die einschlägigen Harmonisierungsrechtsvorschriften der Union:

Richtlinie 2014/53/EU, Richtlinie 2011/65/EU.

Der vollständige Text der EU-Konformitätserklärung kann unter unserer Web-Seite [www.cherubini.it](http://www.cherubini.it), gefragt werden.

### **FR DÉCLARATION UE DE CONFORMITÉ**

CHERUBINI S.p.A. déclare que le produit est conforme à la législation d'harmonisation de l'Union applicable:

Directive 2014/53/UE, Directive 2011/65/UE.

Le texte complet de la déclaration UE de conformité est disponible en faisant requête sur le site internet: [www.cherubini.it](http://www.cherubini.it).

### **ES DECLARACIÓN UE DE CONFORMIDAD**

CHERUBINI S.p.A. declara que el producto es conforme con la legislación de armonización pertinente de la Unión:

Directiva 2014/53/UE, Directiva 2011/65/UE.

El texto completo de la declaración UE de conformidad puede ser solicitado en: [www.cherubini.it](http://www.cherubini.it).





## NOTE

---

---

---

---

---

---

---

---

---

---

---

---

---

---

---

---

---

---

---

---

---

---

## NOTE

---

---

---

---

---

---

---

---

---

---

---

---

---

---

---

---

---

---

---

---

---

---



**CHERUBINI S.p.A.**

Via Adige 55  
25081 Bedizzole (BS) - Italy  
Tel. +39 030 6872.039 | Fax +39 030 6872.040  
info@cherubini.it | www.cherubini.it

**CHERUBINI Iberia S.L.**

Avda. Unión Europea 11-H  
Apdo. 283 - P. I. El Castillo  
03630 Sax Alicante - Spain  
Tel. +34 (0) 966 967 504 | Fax +34 (0) 966 967 505  
info@cherubini.es | www.cherubini.es

**CHERUBINI France SAS**

ZI Du Mas Barbet  
165 Impasse Ampère  
30600 Vauvert - France  
Tél. +33 (0) 466 77 88 58  
info@cherubini.fr | www.cherubini.fr

**CHERUBINI Deutschland GmbH**

Siemensstrasse, 40 - 53121 Bonn - Deutschland  
Tel. +49 (0) 228 962 976 34 / 35 | Fax +49 (0) 228 962 976 36  
info@cherubini-group.de | www.cherubini-group.de

